

# MAGNETIC TYPE SPEED RELAY

The Speed Relay is a magnetic type motion sensor specifically designed to detect the speed of a rotating shaft in machinery. If an overload causes a shaft speed to decrease abnormally, or to increase dangerously, the Speed Relay will immediately output an alarm signal to prevent problems.



## Features

- **No power supply is required**  
 The Speed Relay is actuated when the setting speed is mechanically detected.
- **No maintenance is required.**  
 The Speed Relay can be operated continuously over a long period without lubrication or inspection.
- **Superior durability is secured by its rigid structure.**  
 More than 45,000 installations show that the speed relay is high-quality and field-proven.

## Structures and Operation

- The Speed Relay consists of a permanent magnet that rotates together with the shaft, a rotor generating a torque proportional to the rotational speed of the shaft, two micro switches to be actuated depending on the rotation direction, and an actuating rotational speed adjustment mechanism.
- The metal rotor easily allows penetration of the magnetic line of force, and is fixed with two rotor supports that allow it to operate smoothly. The contact operating lever installed below the rotor supports is centrally supported (as shown) with setting springs to prevent the rotor from running idle.
- When the permanent magnet rotates, an induced current proportional to the rotational speed flows in the squirrel-cage conductor which has been incorporated inside the rotor. This current is induced in the same principle as a squirrel-cage motor, so that a torque with the same direction as the permanent magnet is produced in the rotor.
- The higher the shaft speed, the larger the torque. The rotor operates beyond the force of the setting spring, and switches the microswitch contact.

- As the rotational speed of the shaft decreases, the setting spring pushes the contact operating lever back to the center position to reset the switch. In other words, the actuating rotational speed will vary depending on the force of the setting spring.

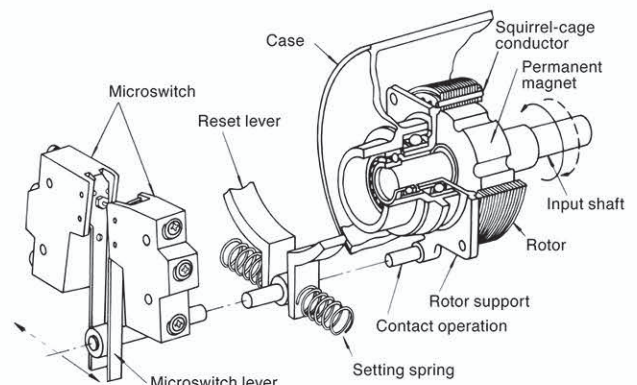





**Dust-ignition proof type SDP13 Touch roller type ESRDP Series**

**Appearance and Dimensional Drawing**



※ ESRDP-323N  
N: Installation base.  
Lead outlet

|                      |                      |           |           |
|----------------------|----------------------|-----------|-----------|
| Type                 |                      | ESRDP-103 | ESRDP-123 |
|                      |                      | ESRDP-303 | ESRDP-323 |
| Max. Allowable speed |                      | 300m/min  | 300m/min  |
| Speed down           | Min. Rated speed     | 35m/min   | 53m/min   |
|                      | Min. Actuating speed | 24m/min   | 37m/min   |

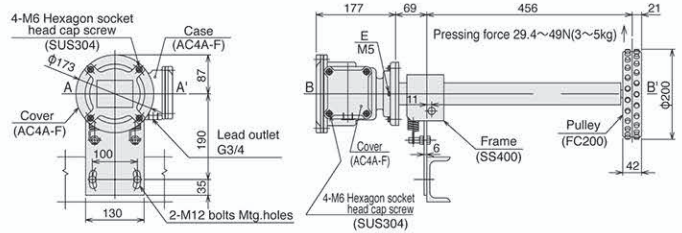

| Type      | Dimension (mm) |     |    |    | Mass   |
|-----------|----------------|-----|----|----|--------|
|           | φa             | b   | c  | d  |        |
| ESRDP-103 | 130            | 306 | 19 | 38 | 15.5kg |
| ESRDP-123 | 200            | 306 | 21 | 42 | 16kg   |
| ESRDP-303 | 130            | 456 | 19 | 38 | 16kg   |
| ESRDP-323 | 200            | 456 | 21 | 42 | 16.5kg |

**Dust-ignition proof type SDP13 ESRDP-200B with shaft end key / Mass: 7.5kg**

**Appearance and Dimensional Drawing**



|                      |                      |          |
|----------------------|----------------------|----------|
| Max. Allowable speed |                      | 1800 rpm |
| Speed up             | Min. Rated speed     | 60 rpm   |
|                      | Min. Actuating speed | 78 rpm   |
| Speed down           | Min. Rated speed     | 86 rpm   |
|                      | Min. Actuating speed | 60 rpm   |

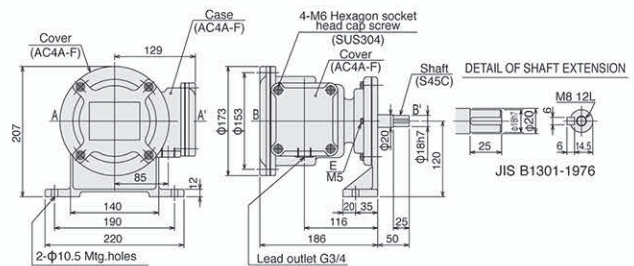

**Explosion proof type d2G4 Base-type ESRM-100B with shaft end key / Mass: 37kg**

**Appearance and Dimensional Drawing**



|                      |                      |          |
|----------------------|----------------------|----------|
| Max. Allowable speed |                      | 1800 rpm |
| Speed up             | Min. Rated speed     | 60 rpm   |
|                      | Min. Actuating speed | 78 rpm   |
| Speed down           | Min. Rated speed     | 86 rpm   |
|                      | Min. Actuating speed | 60 rpm   |

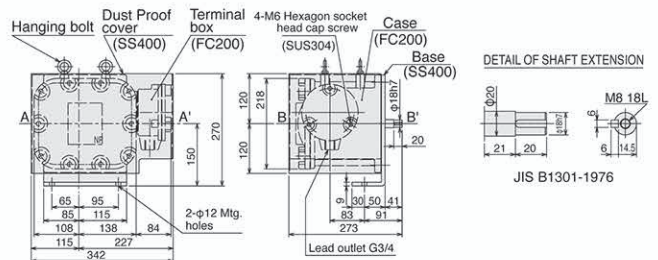

Note 1) A-A' and B-B' of the drawings should be horizontal from the viewpoint of internal structure.

Note 2) Specifications and dimensions are subject to change for product improvement.

Note 3) Flange type can be used as IP 55 by sealing the front of the mounting base.

**Standard Specifications**

|                     |  |
|---------------------|--|
| Contact capacity    | AC250V 5A Resistance load<br>DC125V 0.5A Resistance load |
| Ambient temperature | -10°C ~ +50°C  |
| Protection class    | IP55(Flange type IP 40), see Noto 3)                     |
| Coating color       | Munsell 7.5GY 6/10                                       |
| Tolerance           | +/-10%   |
| Shaft               | New JIS key  |

**Necessary Specificateins**

Type :

Rated speed : rpm or m/min

Actuating speed

Actuation at speed up : rpm or m/min

Actuation at speed down : rpm or m/min

Contact type : NC contact (zero speed : ON)  
NO contact (zero speed : OFF)

How to decide setting speed (actuating speed)  
(in condition of standard microswitch)

A Speed up : 70% or less of rated speed

B Speed down: 130% or more of rated speed

## Selection of Actuating Speed

The actuating speed of speed relay is different between at speed up and at speed down. When determining this specification, designate the speed up or speed down actuation. In addition, refer to the following criteria when determining the actuating speed. When selecting an actuating speed that is not included in the following criteria, the speed relay may not actuate due to MD (Movement Differential:20-25%)

### Overspeed detection

Actuation at speed up: The actuating speed should be 130% or more of the rated speed.

### Belt slip detection

Actuation at speed down: The actuating speed should be 70% or less of the rated speed.

### Speed-down actuation

When the microswitch actuates at 70% against the rated speed 100%, the rotation speed at which the microswitch recovers is 90 - 95%(MD: Movement Differential) while the speed is increasing after actuation.

### Speed-up actuation

When the microswitch actuates at 130% against the rated speed 100%, the speed at which the microswitch recovers is 105 - 110% (MD: Movement Differential) while the speed is decreasing after actuation.

※Contact us if the DC type switch is required because it needs more MD(Movement Differential) for recovery.

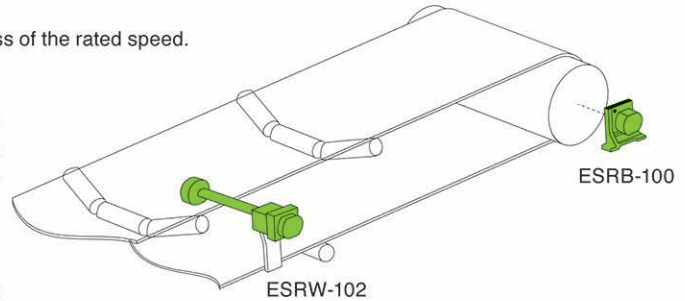

Figure 1 Mounting image

## Examples of Application

### Belt conveyor slip detection (refer to Figure 2)

### Overload / fault detection in machine (refer to Figure 2)

Press the START button to activate the motor(M).

Because the contact SS of the speed relay is OFF at this time, set the timer contact TR to ON until the speed rises and the contact SS turns ON. When the speed drops, the contact SS of the speed relay will turn OFF and the motor will stop. Usually, the control circuit incorporates a circuit that outputs the alarm in synchronization with the motor stopping.

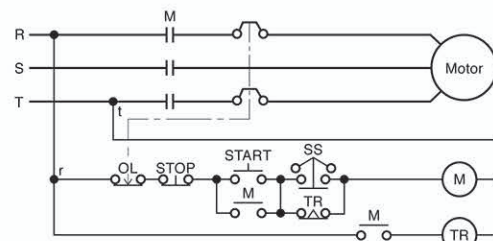

Figure 2 Example of circuit for slip detection and overload detection

### Control for sequential activation and deactivation of the conveyor (refer to Figure 3)

Press the START button to activate the motor(1M). When the rotational speed of the motor exceeds 90 - 95% of the rated speed, the contact 1SS of the speed relay will turn ON and the motor(2M) will be activated. The other four motors are activated in the same way.

Press the STOP button to sequentially turn OFF the timers from 4TR to 1TR, and to deactivate the motors from M4 to M1 in sequence.

### Overspeed detection

In case the equipment such as crane enters a dangerous overspeed, the STOP button is connected in series to the contact of the speed relay for emergency stop. In this case, select the actuating speed so that the contact will turn OFF when the speed of equipment exceeds 130% of the rated speed.

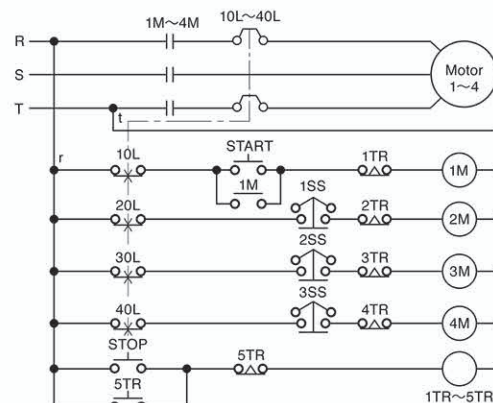

Figure 3 Example of control circuit for sequential activation and deactivation



Caution  
 ●Read the instructions to ensure correct and suitable application of products.  
 ●Contact our nearest sales office when using our products for any systems used in situations which may be life threatening.

Specifications are subject to change without notice.

All Rights Reserved Copyrights©2017, Matsushima Measuretech Co., Ltd.

Distributor



## Matsushima Measure Tech Co., Ltd.

HEAD OFFICE  
 1-8-18, NORIMATSU-HIGASHI, YAHATANISHI-KU, KITAKYUSHU, 807-0837 JAPAN  
 Tel: +81-93-691-3731 FAX: +81-93-691-3735  
<http://www.matsushima-m-tech.com> E-mail: info@matsushima-m-tech.com

Pohang Representative Office  
 Odyssey Bldg. 1F, 41, Jukdo-ro 28beon-gil, Buk-gu, Pohang-si, Gyeongsangbuk-do, 791-841, Korea  
 Tel: +82-(0)54-274-3731 FAX: +82-(0)54-274-3731

Affiliated company  
 Shanghai Dahong Matsushima Machinery Co., Ltd.  
 70 Hengchang Road, Dahong, Malu, Jiading, Shanghai 201818, China  
 Tel: +86-(0)21-5951-4138 FAX: +86-(0)21-5951-4139